

Technical Support

For all technical support inquiries, please visit the mySAFE section on our website at www.xitel.com. If you can't find an answer to your problems there, contact us via email: support@www.xitel.com.

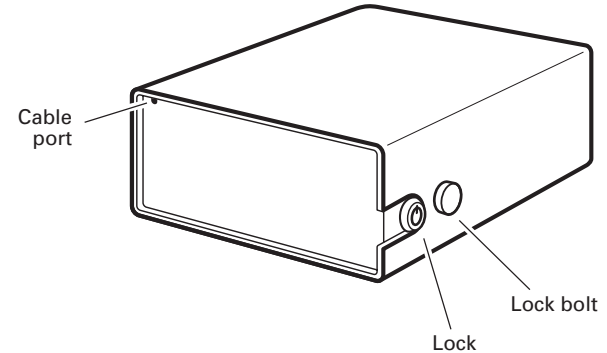

Auto Lockbox



Warranties and Disclaimer

The actual physical dimensions and capabilities of mySAFE Lockbox may differ slightly from illustrations and descriptions contained in this manual or displayed on the box. Every effort has been made to ensure that functionality has been maintained wherever possible. Xitel reserves the right to change specifications of the mySAFE Lockbox or bundled items without notice. Xitel warrants the mySAFE Lockbox against defects in material and workmanship for one year from the date of original purchase from an authorized dealer or mySAFE representative. This warranty only applies to the original purchaser and is not transferable. At Xitel's sole discretion, proof of purchase and/or mySAFE serial number will be required to initiate any warranty claim. This warranty does not cover normal wear and tear, any damage caused by negligence, non-authorized modifications, service by any persons other than Xitel or its nominated agent, or if the product has been damaged by Act of God, accident, abuse, misuse, negligence, misapplication, foreign matter entering the product (including but not limited to: liquid, moisture, insects, dirt or sand), or has been used in any other way other than in strict accordance with the instructions set out in this user manual or any other documentation Xitel may include in the retail package. In the event that mySAFE Lockbox should prove defective, customer's sole remedy shall be strictly limited to the repair or replacement of mySAFE Lockbox. By using mySAFE Lockbox, customer acknowledges that mySAFE Lockbox is a preventative security device designed to deter theft only and accepts that like all safes and other lockable containers, the protection offered by mySAFE is not infallible. Under no circumstances is Xitel responsible for any property loss, theft, lost profits, lost savings or other incidental or consequential damages arising out of the use of, or inability to use, this product. That includes loss or damage to property and, to the extent permitted by law, damages for personal injury. This warranty is in lieu of all other warranties including implied warranties of merchantability and fitness for a particular purpose to the extent permitted by law.

©2009 Xitel Pty. Ltd.

What's in the box:

- mySAFE Lockbox Outer
- mySAFE Lockbox Inner
- Security Cable
- Lock Bolt
- Keys

Using your mySAFE Lockbox

Your mySAFE Lockbox comes with a Lock Bolt and Security Cable. Use the Lock Bolt when carrying your mySAFE around. Use the Security Cable to lock your mySAFE to an immovable object in your car, truck, RV, home, office or dorm.

If you're using the Security Cable, attach it to an immovable object in the following way:

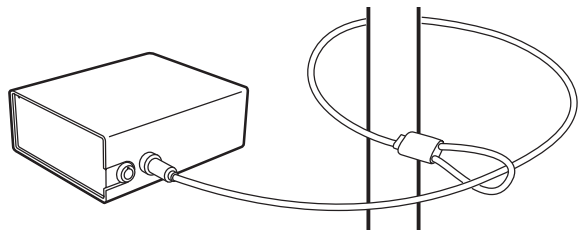

Place the items that you want to protect into the inner tray.

If you have any items you want to recharge while locked inside, slip the power cable through the cable port. Please check the user manual of the product you're recharging for any recharging precautions.

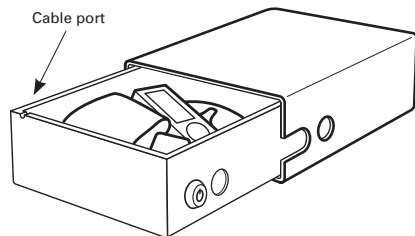

With the key in a vertical position, insert the Lock Bolt or bolt end of the Security Cable into the lock hole.

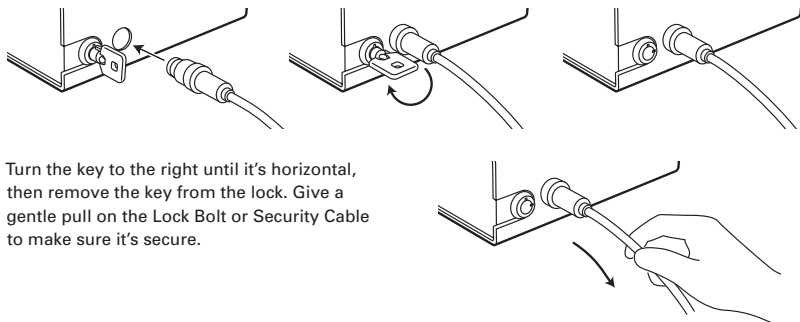

Turn the key to the right until it's horizontal, then remove the key from the lock. Give a gentle pull on the Lock Bolt or Security Cable to make sure it's secure.

Opening mySAFE

Place your mySAFE so that it's sitting flat. Insert the key into the lock and turn it to the left until vertical. Remove the Bolt Lock or Security Cable from the lock hole.

WARNING: at this stage the tray will be loose in the inner. We recommend that you don't pick up your mySAFE until you have removed your valuables.

Carefully slide the inner tray forward to remove your valuables.

After your valuables have been removed, slide the inner tray back into the outer and lock the Lock Bolt or Security Cable in place.

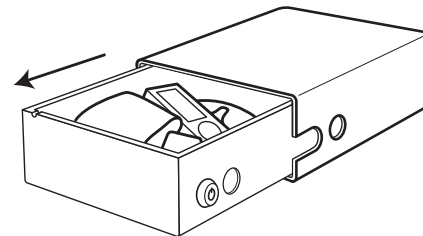

Keep Concealed

mySAFE is a preventative security device designed to deter theft. While we have taken the utmost care in creating a highly secure product, no lockbox or safe can offer infallible protection. We recommend concealment of your valuables even when using mySAFE. In a vehicle, store your mySAFE under a seat or in the trunk where it is not visible.



Avoid Direct Sunlight

Avoid placing your mySAFE Lockbox in direct sunlight for long periods of time. Direct sunlight, especially during summer, can heat up the metal case and cause it to become very hot, potentially damaging sensitive electronic products you may be keeping safe inside.